

VME System Subracks 3 U / 4 U

User's Manual



Product Numbers:
20836-310 20836-415

Doc-No: 63972-153

Revision: R1.0, June 25, 2007

Rev.	Date updated	Change
R1.0	June 25, 2007	Initial Release

Impressum:

Schroff GmbH

D-75334 Straubenhardt, Germany

The details in this manual have been carefully compiled and checked - supported by certified Quality Management System to EN ISO 9001/2000

The company cannot accept any liability for errors or misprints. The company reserves the right to amendments of technical specifications due to further development and improvement of products.

Copyright © 2007

All rights and technical modifications reserved.

1 Safety	0
1.1 Intended Application.....	0
1.2 Safety Instructions.....	0
1.2.1 Safety Symbols used in this document.....	0
1.3 General Safety Precautions.....	1
1.4 References and Architecture Specifications	1
2 Equipment description	2
2.1 Subrack Systems Overview.....	3
2.2 Subracks:	4
2.3 VME Systems Backplane	4
2.4 Power Supply	4
2.4.1 Grounding/Earthing	5
2.5 Cooling.....	6
2.6 Fan Control Module (FCM).....	7
2.7 Chassis Monitoring Module (CMM) -optional-.....	8
2.8 Display Module.....	9
3 Assembly	10
3.1 General Assembly Guidelines	10
3.1.1 Unpacking	10
3.1.2 Ensuring Proper Airflow	10
3.2 Rack-Mounting.....	10
3.3 Commissioning.....	12
4 Service	13
4.1 Technical support and Return for Service Assistance.....	13
4.2 Declaration of Conformity	13
4.3 Delivery comprises.....	13
4.4 Accessories.....	14
4.5 Replacement Parts.....	14
5 Technical Data	14
6 Dimensions	16

I

1 Safety

1.1 Intended Application

The VME system subrack, described in this manual, is intended as a platform for a microcomputer system based on the VME bus system (VITA 1-1994). The VME system subracks are designed for protection class IP 20 and can be used only in the resp. environments. For higher protection requirements, a.e. IP 54/55 you must install the system subrack in a protective case.

VME system subracks are not finished products, so there is no valid approval for these units. In order to enable stand-alone functionality, additional elements are required. An operational system is achieved only by way of appropriate VME boards.

The completion and final testing of the units have been carried out, or at least supervised, by qualified technicians. These instructions are directed exclusively to these qualified technicians i.e. engineers, trained and qualified electricians etc.



Make sure that:

- the assembled unit complies with the safety regulations currently applicable in the country it is going to be used.
- the overall unit complies with all other regulations and specifications at the place and country of use, e.g. interference limits, approval by the telecommunications authorities.

1.2 Safety Instructions

The intended audience of this User's Manual is system integrators and hardware/software engineers.

1.2.1 Safety Symbols used in this document

	<p>Hazardous voltage!</p> <p><i>This is the electrical hazard symbol. Familiarise yourself with the danger of electrical voltages and the safety precautions to avoid accidents before starting to work with parts that carry dangerous voltages.</i></p>
	<p>Caution!</p> <p><i>This is the user caution symbol. It indicates a condition where damage of the equipment or injury of the service personnel could occur. To reduce the risk of damage or injury, follow all steps or procedures as instructed.</i></p>

	<p>Danger of electrostatic discharge!</p> <p><i>Static electricity can damage sensitive components in a system. To avoid damage, wear ESD wrist straps or at regular intervals touch blank enclosure parts.</i></p>
---	--

1.3 General Safety Precautions

	<p>Warning!</p> <p><i>Voltages over 60 VDC can be present in this equipment. This equipment is intended to be accessed, to be installed and maintained by qualified and trained service personnel only.</i></p> <p><i>This equipment is designed in accordance with protection class 1!</i></p> <p><i>It must therefore be operated only with protective GND/earth connection!</i></p>
---	---

- Service personnel must know the necessary electrical safety, wiring and connection practices for installing this equipment in a telecommunication environment.
- Install this equipment only in compliance with local and national electrical codes.

1.4 References and Architecture Specifications

- User Manual VME Backplanes Order no.: 73972-103
- Short Form User Manual VME J1/J2 Monolithic Backplanes Order no.: 73972-128
- User Manual Fan Control Module (FCM) Order no.: 73972-083

Further information can also be found in the catalogue „Electronic Packaging“ and on the internet under www.schroff.biz

2 Equipment description

The Schroff VME plug-in system consists of:

- A shielded 19" subrack with board cage for the assembly of 6 U boards in accordance with VME standard (VITA 1-1994)
- A VME (VITA 1-1994) systems backplane
- An AC power supply with global input range
- Fans for the active cooling of the boards
- Fan Control Module (FMC) to control the cooling
- Display module
- AC switch

The power supply the Axial fans and the Fan Control Module are assembled at the right behind a perforated front panel. The display module is at the top of the front panel and the AC mains switch is at the bottom. At the rear panel is the mains input module with IEC 320-C14 connector, line filter and fuses.

Unit versions:

The subrack systems 20836-310/-415 are identical apart from their different height. The 3 U system 20836-310 enables the assembly of 5 VME boards, the 4 U system enables the assembly of 8 VME boards. The performance of fans and the power supply is adapted to the number of slots.



The systems can be assembled customer specific with all in the catalogue available system components by the Assembly Service from Schroff:

- *The individual configuration includes e.g.:*
- *assembly of other backplanes*
- *assembly of drive units*
- *assembly of power supplies corresponding to the system requirements*
- *assembly of a Chassis Monitoring Module (CMM) to monitor the system*

Further information can be found in the catalogue or under: www.schroff.biz

2.1 Subrack Systems Overview

Figure 1: Subrack Systems Overview

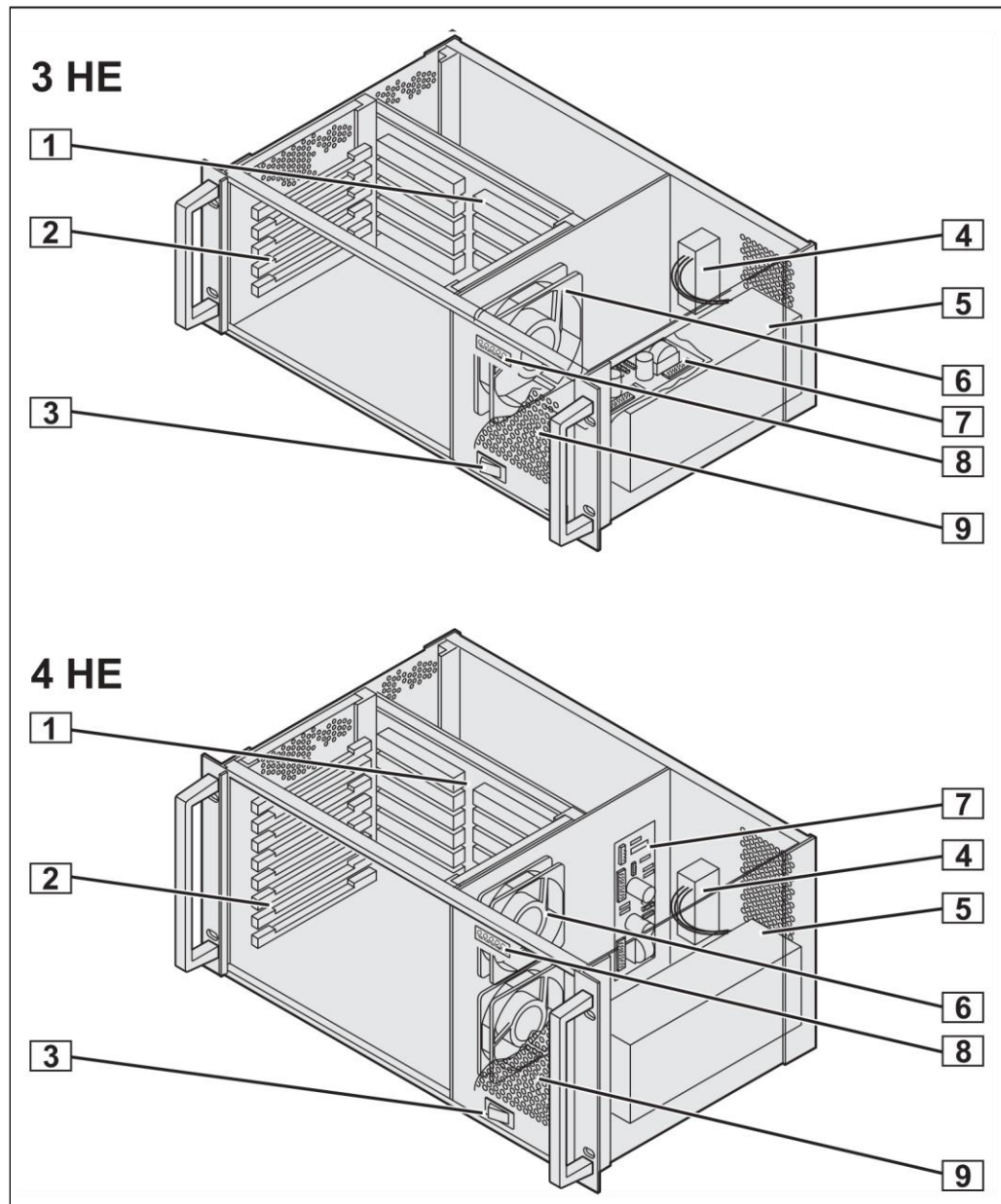

10006829

- | | | | |
|---|--|---|-------------------------------|
| 1 | VME systems backplane | 6 | Axial fan |
| 2 | Board cage with guide rails | 7 | Fan Control Module (FCM) |
| 3 | Mains/line switch | 8 | Display module |
| 4 | Mains Input Module with IEC 320-C14 connector, line filter and fuses | 9 | Front panel 28 HP, perforated |
| 5 | Power supply | | |

2.2 Subracks:

The 3 U or 4 U 19" subrack is based on the Schroff europacPRO system with EMC shielding. The board cage enables the horizontal assembly of 5 (3 U system) or 8 (4 U system) VME boards with dimensions: 6 U, 4 HP, 160 mm deep.

The right guide rails of the board cage are equipped with ESD clips.

2.3 VME Systems Backplane

The horizontally assembled 6 U backplane (J1.J2 Monolithic) conforms to:

VITA 1-1994

VITA 38 systems management for VME

The system 20836-310 is supplied with a 5 slot backplane, the system 20836-415 is supplied with a 8 slot backplane. Backplanes with a different number of slots are, however, available as an option.

Further information can be found in the user manual of the backplane: OrderNo. 73972-103/-128, in the catalogue or on the internet under www.schroff.biz



1 Slot = 4 HP = 20.32 mm

2.4 Power Supply

	<p>Hazardous voltage! <i>Parts of the power supply may be exposed with hazardous voltage. Always remove mains/line connector before carry out any assembly work.</i></p>
	<p>Caution! <i>Your system has not been provided with a AC power cable. Purchase a AC power cable that is approved for use in your country. The AC power cable must be rated for the product and for the voltage and current marked on the product's electrical ratings label. The voltage and current rating of the cable should be greater than the ratings marked on the product.</i></p>

The power supply is carried out with an AC power supply with wide range input. The power supply is located to the right of the board cage behind a perforated front panel. The AC input is via a mains input module with IEC 320-C14 connector, line filter and fuses.

The mains on/off switch is located at the bottom of the perforated front panel.

The safeguard of the phase and zero conductor is carried out with 2 fuses at the mains input module.

The maximum allowed fuse value is:

- 5 A with plug-in system 20836-310 with 250 W power supply
- 6.3 A with plug-in system 20836-415 with 350 W power supply

	<p>Warning!</p> <p><i>After the board assembly is complete, the total power intake of the system has to be established and the fuse value has to be adapted accordingly.</i></p>
---	---

2.4.1 Grounding/Earthing

	<p>Caution!</p> <p><i>The unit is designed in accordance with protection class 1! It must therefore be operated with protective earth/GND connection. Use only a three conductor AC power cable with a protective earth conductor that meets the IEC safety standards!</i></p>
---	---

There is a 6.3 mm faston connector at the rear with a grounding symbol. This connector is only for equipotential bonding. Grounding is achieved through the protective earth conductor of the power cable!

Table 1: Technical Data AC Power Supply.

	Power Supply 250 W for 3 U Systems	Power Supply 350 W for 4 U Systems
Nominal Input voltage	100 - 240 VAC	100 - 240 VAC
Frequency	50 / 60 Hz	50 / 60 / 400 Hz
Maximale output power	250 W	350 W
Output voltages	5.0 V - 40 A 12.0 V - 4 A -12.0 V - 1.5 A	5.0 V - 45 A 12.0 V - 10 A -12.0 V - 9.5 A
Ripple	< 1.5 % at 5 V < 1 % at 12 V	< 1 %
Dynamic load step		50 mV at 5 V 3 % at -12 V
Recovery time to within 1%		< 500 µsec
Over voltage protection	for all voltages	for all voltages
Over current protection	Protection against overload and short circuiting	Protection against overload and short circuiting
Hold-up time	>= 16 ms	>= 15 ms



The 250 W power supply for the 3 U System has an additional voltage of 3.3 V / 40 A which is not connected to the backplane but can be used for further applications.

Figure 2: Wiring Diagram

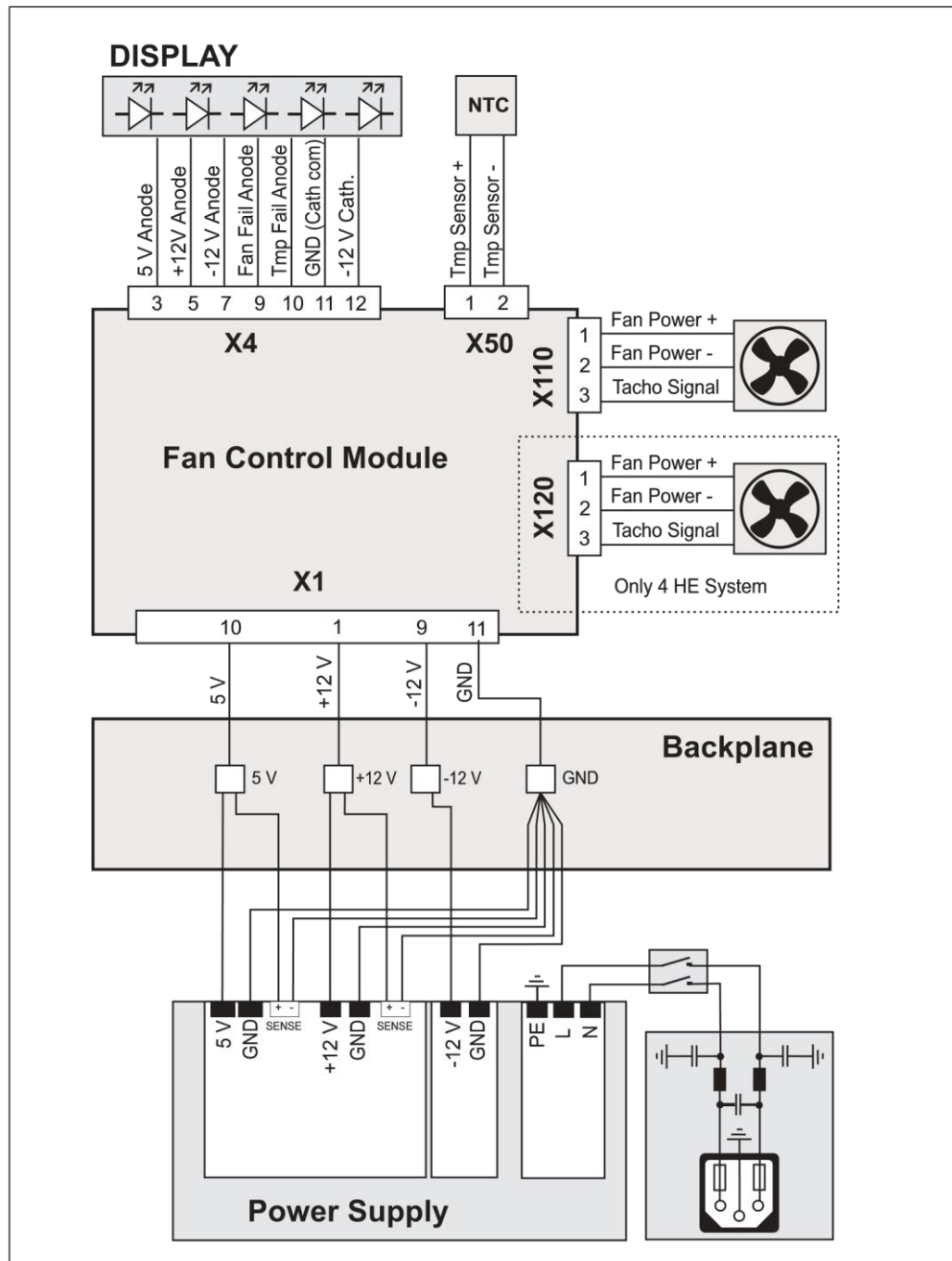

10006831

2.5 Cooling

The front boards are cooled by forced air convection through speed controlled 24 VDC axial fans.



The 3 U unit has an axial fan with a performance of 170 m³/h (100 cfm), with the 4 U unit the cooling is carried out with two axial fans with a performance of 70 m³/h each (42 cfm).

The fans and the Fan Control Module (FCM) are located at the right next to the board cage behind a perforated front panel.

The air enters the subrack at the right perforated front panel and passes across the hot components on the Front Boards. Heat is carried away by forced convection. The air exits the Subrack at the left side.

The fan speed is controlled by the Fan Control Module (FCM) depending on the exhaust temperature.



Caution!

To maintain proper airflow, all open slots must be covered with filler panels. The filler panel should include an airflow baffle that extends to backplane.

Figure 3: Cooling (illustrated on a 4 U system)

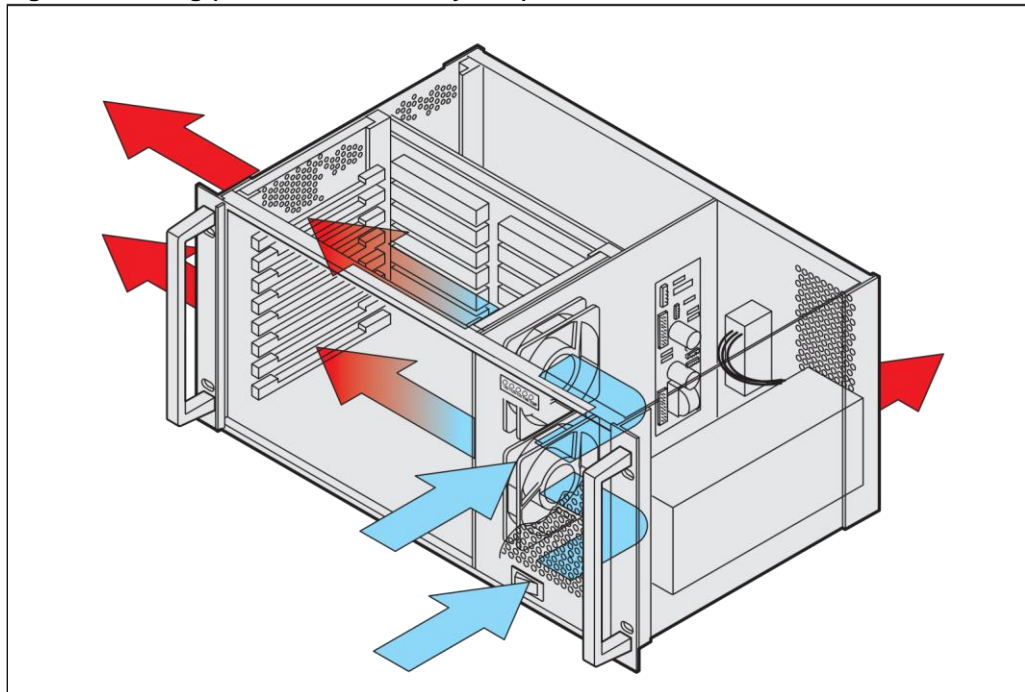

10006830

i The ventilation for the cooling of the boards and the air direction of the power supply are independent from each other. The power supply sucks in the air through a perforated front panel too, but the hot air is expelled through the partly perforated rear panel. During assembly into a rack it must be observed, that no air vents are blocked.

2.6 Fan Control Module (FCM)

The Fan Control Module (FCM):

- Monitors and controls up to four fans
- Monitors the signals from up to four temperature sensors
- Controls the Display Module
- Speed up the fans in case of a failure of one fan

- enable remote monitoring when connected to the optional Chassis Monitoring Module (CMM)

Up to four NTC temperature sensors can be connected to the FCM. The highest temperature level is the reference for the fan speed. If one or more sensors exceed 60° C the output for the temperature fail LED and a digital output are activated. Since the fan speed is temperature controlled by the FCM, the fans rotate with the lowest speed possible. Lower speeds reduce acoustic noise and increase the longevity of the fans.

The FCM also controls a Display Module. 3 green LEDs signal the 3 VME voltages, two red LEDs signal over-temperature and fan fail events.

Figure 4: Hysteresis line for fan speed/temperature

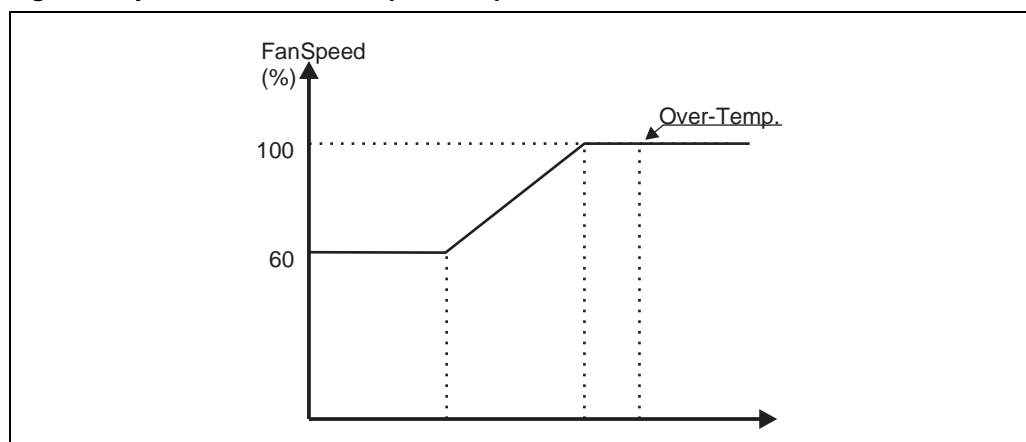

10006807

Further information can be found in the FCM Manual, Order-No. 73972-083 or on the internet under: www.schroff.biz

2.7 Chassis Monitoring Module (CMM) -optional-

The Chassis Monitoring Module (CMM)

- monitors the three VME voltages
- can monitor two further voltages of up to $\pm 24 V_{DC}$
- can monitor up to seven NTC temperature sensors
- can communicate with the Fan Control Module (FCM)
- provides 16 digital inputs
- provides 10 digital outputs

The CMM is an optional assembly and not included with the subrack by default. The CMM is a pluggable unit in the 3 U euroboard format with a 3 U/1 HP front panel and can be assembled at the front side.

The CMM allows communication and remote monitoring via RS-232 or Ethernet interface. The front panel provides a RJ45 connector (Ethernet) and a D-Sub9 connector (RS-232).

A user interface via HTML page is available.

The CMM can monitor the 3 VME voltages and two additional voltages (up to $\pm 24 V_{DC}$). The error status can be displayed by LEDs, through the RS-232 serial interface or via ethernet as a HTML page.

Up to 7 NTC temperature sensors can be connected to the CMM. Two alarm thresholds between 20° C and 70° C can be set.

The CMM provides 16 digital inputs and 10 digital outputs for customer specific applications. Four digital outputs are open collector outputs, isolated by optocouplers, six digital outputs are TTL-compatible non-isolated.

The CMM is connected to the FCM. The temperature values and the fan speeds are transmitted to the CMM.



If a CMM is installed, the systems backplane has to be reduced by one slot.

Detailed information about the CMM can be found in the User Manual, OrderNo. 73972-084 or on the internet under: www.schroff.biz

2.8 Display Module

Figure 5: Display Module

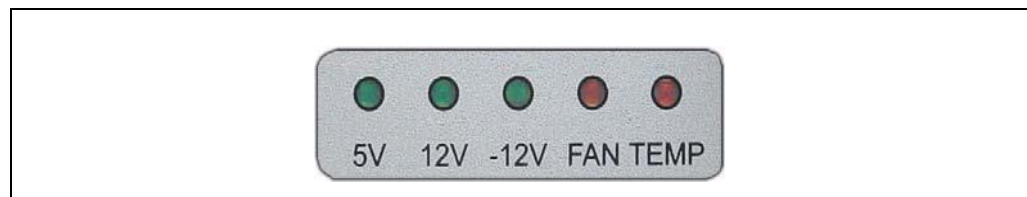

10006821

The display module is located at the top at the right hand side of the system, 3 green LEDs signal the presence of 3 VME voltages, one red LED each signals a fan malfunction and over temperature.

The display module is operated by the FCM.



With a plug-in system equipped with CMM, the display module is operated by the CMM.

3 Assembly

3.1 General Assembly Guidelines

3.1.1 Unpacking

	<p>Caution! <i>When opening the shipping carton, use caution to avoid damaging the system.</i></p>
---	---

Consider the following when unpacking and storing the system:

- Leave the system packed until it is needed for immediate installation.
- After unpacking the system, save and store the packaging material in case the system must be returned.

If the packaging is damaged and possible system damage is present, report to the shipper and analyze the damage.

3.1.2 Ensuring Proper Airflow

- Install the system in an open rack whenever possible. If installation in an enclosed rack is unavoidable, ensure that the rack has adequate ventilation.
- Maintain ambient airflow to ensure normal operation. If the airflow is blocked or restricted, or if the intake air is too warm, an over temperature condition can occur.
- Ensure that cables from other equipment do not obstruct the airflow through the systems.
- Use filler panels to cover all empty chassis slots. The filler panel prevents fan air from escaping out of the front of an open slot.

	<p>Caution! <i>To maintain proper airflow, all open slots must be covered with filler panels. The filler panel should include an airflow baffle that extends to backplane.</i></p>
---	---

3.2 Rack-Mounting

	<p>Warning! <i>Do NOT stack the system on top of any other equipment. If the system falls, it can cause severe bodily injury and damage the equipment.</i></p>
---	---

This subrack system can be installed in 19" equipment racks. The rack must be accessible from the front and rear for equipment installation.

Mounting Instructions:

- Ensure that the rack is constructed to support the weight and dimensions of the system.
- Install any stabilizers that came with your equipment rack before mounting or servicing the system in the rack.
- Load the rack from the bottom to the top, with the heaviest system at the bottom, avoid uneven mechanical loading of the rack.
- Schroff recommends the use of chassis support brackets.

3.3 Commissioning



Warning!

Voltages over 60 VDC can be present in this equipment. This equipment is intended to be accessed, to be installed and maintained by qualified and trained service personnel only.

This equipment is designed in accordance with protection class 1!

It must therefore be operated only with protective GND/earth connection!

Before the commissioning of the system the following tasks have to be carried out:

- Ensure that the system has not been damaged during transport, storage or assembly.
- Carry out a new test for the protective earth – set value < 0.1 Ohm
- Switch on the system and check all VME voltages directly on the backplane before the board assembly
Info: For the regulation of all ports, the 250 W power supply requires a basic load of 4 A on 5 V output ports, which corresponds to a resistance of 1.2 Ohm/20 W.
- Assemble the boards
- Cover the vacant slots with air flow barriers
- Check that the rear panel is screwed on tightly
- Commission the system and measure the total current intake
- Change the power supply fuses at the equipment socket with fuses that correspond to the value of the total current intake.



The power input fuses are arranged for the maximum performance of the power supply and have to be adjusted to the actual current intake of the total system during commissioning.

Maximum values are 5 A (time-lag) with a 250 W power supply and 6.3 A (timelag) with a 350 W power supply.

Figure 6: Power Input Fuses



10006815

1 Fuse

2 AC Power Connector

4 Service

4.1 Technical support and Return for Service Assistance

We generally recommend to return the complete subrack system. For all product returns and support issues, please contact your Schroff sales distributor or www.schroff.biz.

We recommend that you save the packing material. Shipping without the original packing material might void the warranty.

4.2 Declaration of Conformity

VME systems are not an end product. In order to make them operational, further assemblies are necessary.

In accordance with the definition in the EMC directives it is not classified as equipment, therefore a CE certification is not required. The systems do, however, fulfil all requirements in a full assembled state to the standard of EMC guideline 89/336/EWG and the low voltage guideline 73/23/EWG. Generally the systems are equipped with power supplies, which have a CE certification (EN 60950, EN 61000-6-3, EN 61000-6-2).

The selection of the filter elements is carried out with consideration of the hysteresis curve to EN 55022, class B. Interference resistance is guaranteed in accordance with EN 61000-6-2. Shielding measurements in the frequency area of 30 MHz to 1000 MHz to VG directive 95 373, Part 15, are carried out.

The systems were developed and manufactured in accordance with EN 60950. Before delivery each systems undergoes a voltage, protective earth and functionality test.

Service

4.3 Delivery comprises

Quantity	Description
1	19" subrack, shielded, with side panels, rear panel, part front panel and front handles (Front handles: RAL 7016)

VME System Subracks 3 U / 4 U
20836-310/-415

1	VME systems backplane (VITA 1-1994), 5 slot 6 U (3 U systems): 8 slot 6 U (4 U systems):
1	Board cage for the assembly of - max. 5 boards 6 U 160 mm deep (3 U systems) - max. 8 boards 6 U 160 mm deep (4 U systems) Guide rails inc. ESD clips (ESD clip assembled at the front, right)
1	AC mains input module (IEC 320-C14), fuses and filter
1	Open Frame power supply with input range of 100 VAC to 240 VAC 250 W (3 U) with 3 voltages: 5 V/40 A; 12 V/4 A; -12V/1.5 A or 350 W (4 U) with 3 voltages: 5 V/45A; 12 V/10 A; -12V/9.5 A)
1	Complete AC/DC cabling
1	Display module and mains/line switch
2	Speed regulated fans to cool the boards (only 1 fan for 3 U systems)
1	FCM module to monitor and control the fan/s

4.4 Accessories

Order No.	Description
23207-022	Chassis Monitoring Module (CMM)
20848-7xx	Slot covers with front panel and EMC shielding for vacant slots. For dimensions, please see catalogue.
34562-8xx	Slot covers for vacant slots. For dimensions, please see catalogue.
24579-03x	Board covers. For dimensions, please see catalogue
20836-450	19" enclosure for the assembly of plug-in systems (4 U, with 3 U systems with Additional front panel 1 U)

4.5 Replacement Parts

On request.

Technical Data

5 Technical Data

Table 2: Technical Data

Dimensions	
Height (3 U System)	130.92 mm
Height (4 U System)	176.84 mm
Width	483 mm (19")

VME System Subracks 3 U / 4 U
20836-310/-415

Depth	277.5 mm
Weight	
20836-310	5 kg
20836-415	8 kg
Power Supply	
Input Voltage	100 VAC bis 240 VAC
Frequency	50 / 60 Hz (20836-415 auch 400 Hz)
Power input (20836-310)	up to 250 W
Power input (20836-415)	up to 350 W
Cooling	
1 x 24 VDC fan (20836-310)	170 m³/h (100 cfm) each, free blowing
2 x 24 VDC fan (20836-415)	70 m³/h (42 cfm) each, free blowing
Ambient Temperature	
Operation	+0 °C to +40 °C
Storage	-40 °C to +85 °C
Humidity	
Admissible humidity	30 % to 80 %, non-condensing
EMC, fulfils requirements for:	
Transient Emissions	EN 55022
Interference Resistance	EN 55024
Safety	
Test voltages according to EN 60950	Input - Output: 4,3 kVDC Input - PE: 2,2 kVDC Output - PE: 0,7 kVDC Output - Output: 0,7 kVDC
Shock and vibration:	EN 60068-2-6 and EN 60068-2-27
Electromagnetic Shielding	
Shielding attenuation	typ. 40 dB at 1 GHz if shielded front panels are used.

Dimensions

6 Dimensions

Figure 7: Dimensions

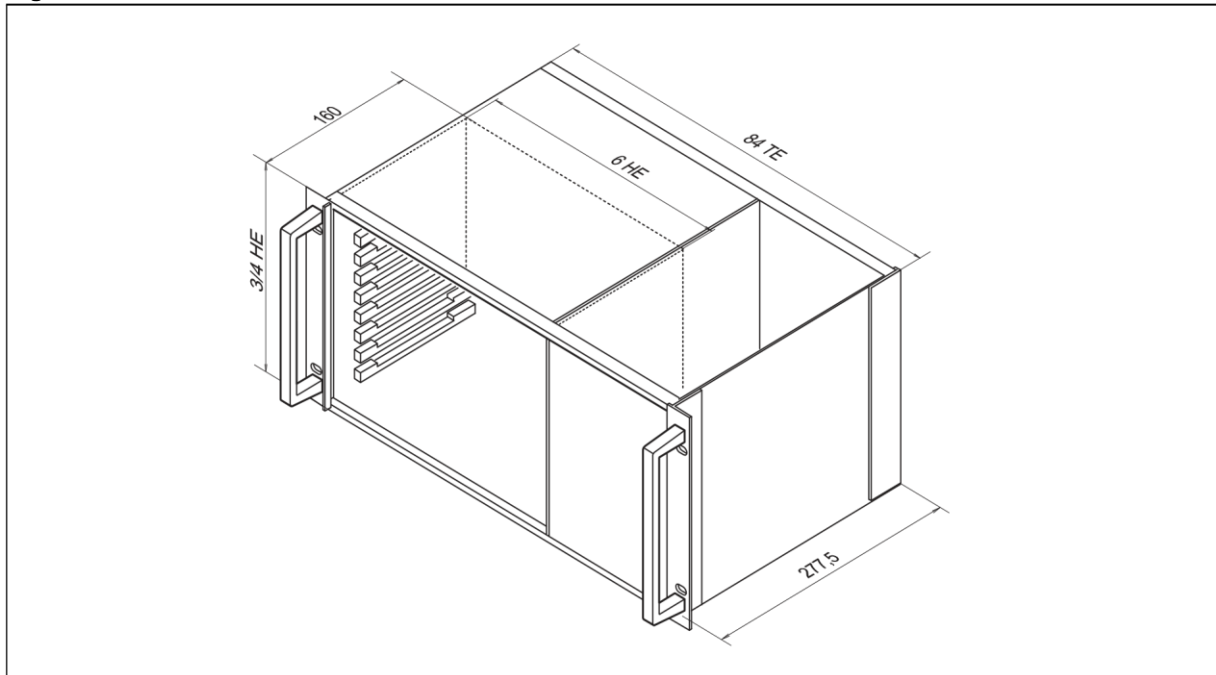

10006832



SCHROFF GMBH

www.schroff.biz

**Langenalberstr. 96-100
D-75334 Straubenhardt**

Tel.: + 49 (0) 7082 794-0

Fax: +49 (0) 7082 794-200